



## FITMENT INSTRUCTIONS

Recovery Trax bracket

# Installation Instructions

---

Preliminary information

Installation and fitment instructions includes the tools required, fasteners included in the kit, and the hardware included in the kit.

Please follow the instructions and check installation steps with the images in this document.

Alu-Cab recommends that all sealing work is allowed to cure for 24 hours, after which you may drive the vehicle on normal paved roads. Before driving off-road with your Alu-Cab product or operating your roof conversion, an additional cure period of 48 hours is required.

Failure to follow these instructions will void your warranty. Please ensure that you follow the sealant manufacturers curing time as per their technical data sheet.

These times may differ slightly from the times we have recommended.

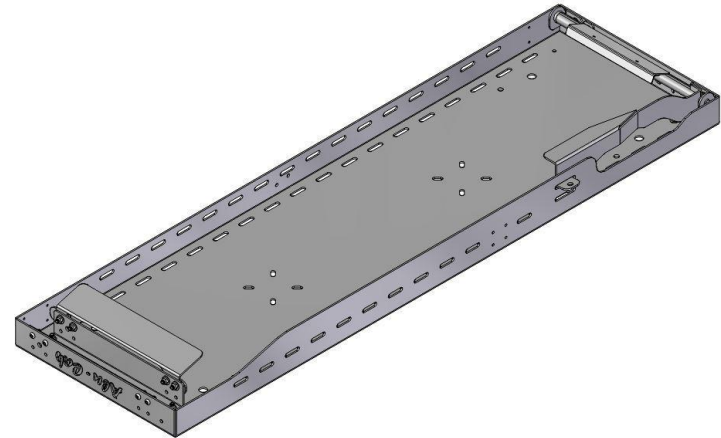

Service Enquiries email  
[queries@alu-cab.com](mailto:queries@alu-cab.com)

# Installation Instructions

## Recovery Trax bracket Fitment – Tools, Fasteners & Hardware

1.1

### Fasteners Supplied

Item	Quantity
Button Head Screw M6x16	14 off
Flat Washer M6	14 off
M6 Nyloc Nut	21 off
M6 Nut Cap	14 off

1.2

### Items

Item	Quantity
411-LOCK-WELD-001-03	1 off
411-MNT-EXT-001-01	1 off
411-TRAY-BASE-001-06	1 off
411-TRAY-MNT-001-01	1 off
411-TRAY-MNT-002-01	1 off
411-TRAY-MNT-003-01	1 off

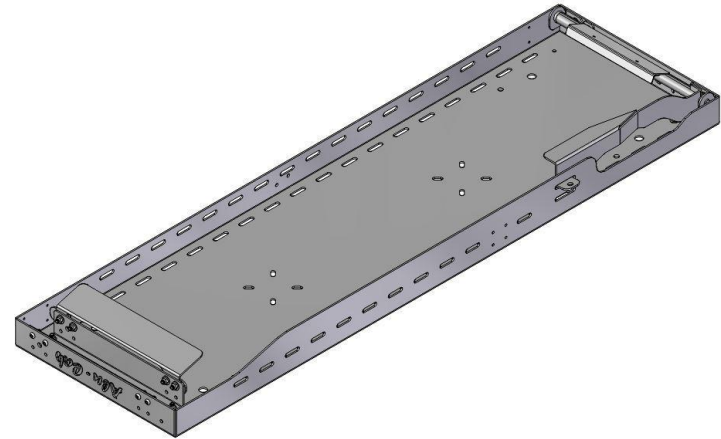

# Installation Instructions

## Recovery Trax bracket Fitment – Tools, Fasteners & Hardware

1.3

Laser cut part



1x Powdercoat Black

Fig. 1: 411-TRAY-BASE-001-06



1x Tumble

Fig. 2: 411-LOCK-WELD-001-03



1x Tumble

Fig. 3: 411-TRAY-MNT-001-01



1x Tumble

Fig. 4: 411-MNT-EXT-001-01



1x Tumble

Fig. 5: 411-TRAY-MNT-002-01



1x Tumble

Fig. 6: 411-TRAY-MNT-003-01

# Installation Instructions

## Recovery Trax bracket Fitment – Tools, Fasteners & Hardware

---

STEP  
1

Weld the four (4) corners of part 411-TRAY-BASE-001-06 closed. See Fig. 7.

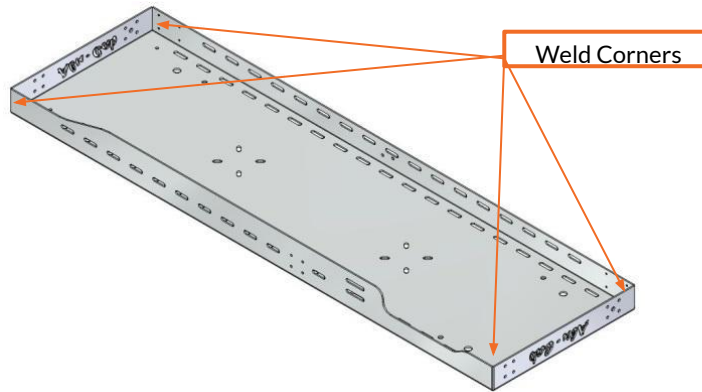

STEP  
2

Send trax table assembly to powder coating to be coated.

# Installation Instructions

## Canopy Camper Fitment – Tools, Fasteners & Hardware

STEP  
3

Mount part 411-TRAY-MNT-002-01 to the Tray assembly. Place bracket 411-TRAY-MNT-002-01 on inside of tray. Use Button-head screw M6x16, M6 flat washer and M6 nylock nut, see fig. 8.

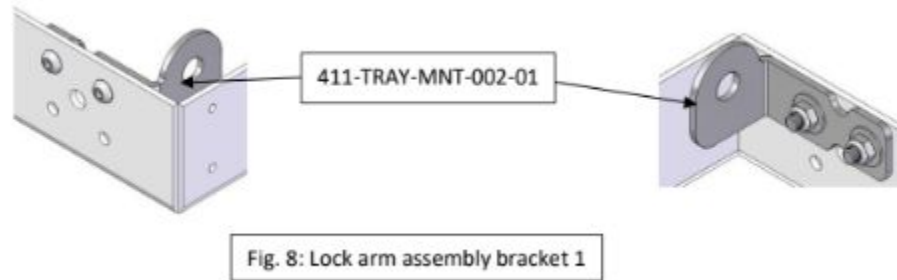

# Installation Instructions

STEP  
4

Mount part 411-LOCK-WELD-001-03 and 411-TRAY-MNT-003-01 to the Tray assembly.

Slide 411-LOCK-WELD-001-03 into lock arm bracket 1.

Place bracket 411-TRAY-MNT-003-01 on weldment and hold in place.

Use Button-head screw M6x16, M6 flat washer and M6 nylock nut, see fig. 9.

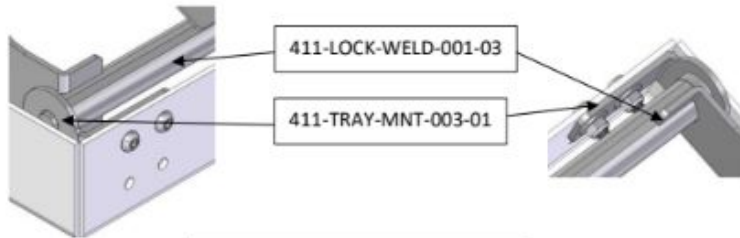

Fig. 9: Lock arm assembly bracket 2

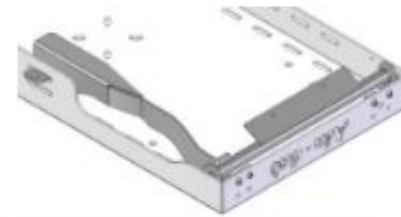

Fig. 10: Lock arm full assembly.

# Installation Instructions

STEP  
5

Mount part 411-MNT-EXT-001-01 to the Tray assembly. Place bracket 411-MNT-EXT-001-01 on inside of tray. Use Button-head screw M6x16, M6 flat washer and M6 nylock nut, see fig. 11.

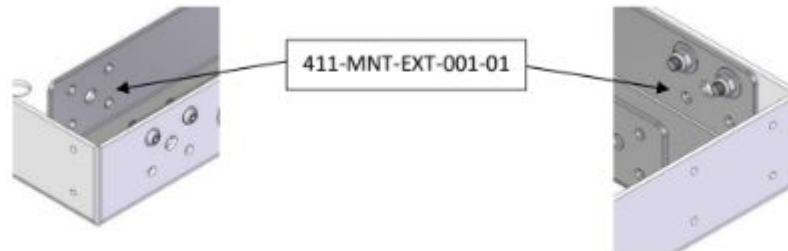
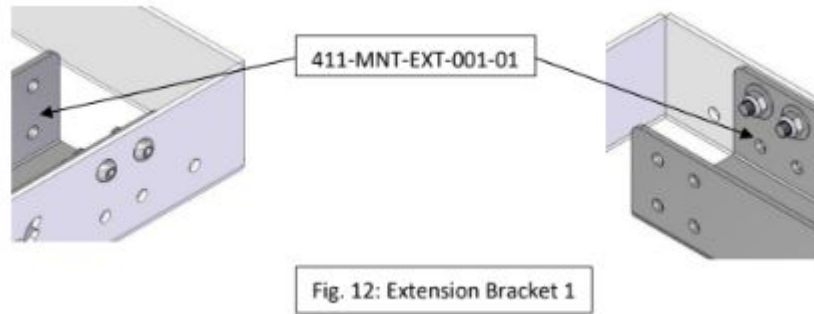

Fig. 11: Extension Bracket 1

# Installation Instructions

STEP  
6

Mount part 411-MNT-EXT-001-01 to the Tray assembly. Use Button-head screw M6x16, M6 flat washer and M6 nylock nut, see fig. 12.



# Installation Instructions

STEP  
7

Mount part 411-MNT-EXT-001-01 to the Tray assembly. Use Button-head screw M6x16, M6 flat washer and M6 nylock nut, see fig. 13.

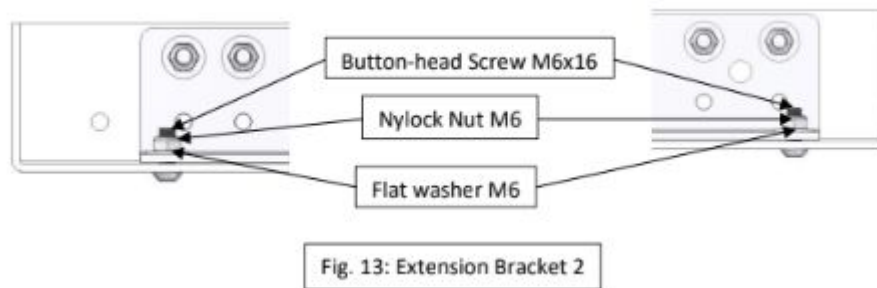

# Installation Instructions

STEP  
8

Mount part 411-TRAY-MNT-001-01 to the 411-MNT-EXT-001-01. Use Button-head Screw M6x16, M6 flat washer and M6 nylock nut, see fig. 14.

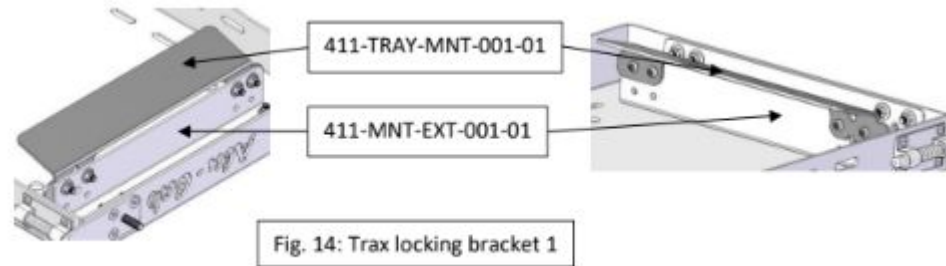

# Disclaimer

---

All rights reserved. No part of this website may be reproduced, translated, stored in a retrieval system, or transmitted, in any form or by any means, electronic, mechanical, photocopying, recording or otherwise, without prior written permission of the owner.

## **Review all instructions information carefully before installation.**

Any damages, direct or incidental to the installer and/or property due to incorrect installation of any parts are the responsibility of the installer. Due to the various applications and fitment options available, the responsibility lies with the user to ensure all mounting points are secure and tight before every trip.

If unsure, consult with your Distributor regarding the operations of our products.

Users are advised to be mindful of the load they are carrying and drive in accordance with road conditions.

## **WARNING**

Always wear appropriate PPE (Personal protection equipment) when fitting our products. Although the mounting kit is designed to be DIY, if you have any doubts or concerns, contact an accredited fitment centre to carry out the work. Alu-Cab will not be liable for any injury to persons, and/or damage to products and/or vehicles.

While Alu-Cab Holdings takes reasonable measures to ensure that the contents of this Website are accurate and complete, Alu-Cab Holdings makes no representations or warranties, whether express or implied, as to the quality, timeliness, operation, integrity, availability or functionality of this Website or as to the accuracy, completeness or reliability of any information on this Website. Alu-Cab Holdings reserves the right to make changes, corrections and/or improvements to the information and to the products and programs described in such information, at any time without notice.

Alu-Cab Holdings will use reasonable endeavours to maintain the availability of the Website, except during scheduled maintenance periods, and reserves the right to discontinue providing the Website or the service or any part thereof with or without notice to you. Any person who accesses this Website or relies on this Website or on the information contained in this Website does so at his or her own risk.

Occasionally, at our discretion, we may include or offer third-party products or services on our website. These third-party sites have separate and independent privacy policies. We therefore have no responsibility or liability for the content and activities of these linked sites. Nonetheless, we seek to protect the integrity of our site and welcome any feedback about these sites.